

Axia Router Selector Node

Installation & User's Guide



Manual Version 2.5 rev May, 2009
Node Software 2.5.2g and higher

IMPORTANT NOTE:

Axia nodes are intended for use with an Ethernet Switch that supports multicast and QoS (Quality of Service). On a non-switched Ethernet hub, or a switch that is not enabled for multicast, this will result in network congestion that could disrupt other network activity.

USA Class A Computing Device Information To User. Warning:

This equipment generates, uses, and can radiate radio-frequency energy. If it is not installed and used as directed by this manual, it may cause interference to radio communication. This equipment complies with the limits for a Class A computing device, as specified by FCC Rules, Part 15, Subpart J, which are designed to provide reasonable protection against such interference when this type of equipment is operated in a commercial environment. Operation of this equipment in a residential area is likely to cause interference. If it does, the user will be required to eliminate the interference at the user's expense. NOTE: Objectionable interference to TV or radio reception can occur if other devices are connected to this device without the use of shielded interconnect cables. FCC rules require the use of only shielded cables.

Canada Warning:

“This digital apparatus does not exceed the Class A limits for radio noise emissions set out in the Radio Interference Regulations of the Canadian Department of Communications.” “Le present appareil numerique n’emet pas de bruits radioelectriques depassant les limites applicables aux appareils numeriques (de les Class A) prescrites dans le Reglement sur le brouillage radioelectrique edicte par le ministere des Communications du Canada.”

Important Safety Information

To reduce the risk of electrical shock, do not expose this product to rain or moisture. Keep liquids away from the ventilation openings in the top and rear of the unit. Do not shower or bathe with the unit.

Caution

The installation and servicing instructions in the manual are for use by qualified personnel only. To avoid Electric Shock, do not perform any servicing other than that contained in the operating instructions unless you are qualified to do so. Refer all servicing to qualified personnel.

Electrical Warning

To prevent risk of electric shock: Disconnect power cord before servicing.

This equipment is designed to be operated from a power source that includes a third “grounding” connection in addition to the power leads. Do not defeat this safety feature. In addition to creating a potentially hazardous situation, defeating this safety ground will prevent the internal line noise filter from functioning.

Ventilation Warning

The Axia 8x8 node uses convection cooling. Do not block the ventilation openings in the side or top of the unit. Failure to allow proper ventilation could damage the unit or create a fire hazard. Do not place the unit on a carpet, bedding, or other materials that could interfere with the rear and top panel ventilation openings.

Customer Service

We support you...

By Phone/Fax in the USA.

- Customer service is available from 9:30 AM to 6:00 PM USA Eastern Time, Monday through Friday at +1 216.241.7225. Fax: +1 216.241.4103. The 24-hour Telos/Omnia/Axia support line is +1 216.622.0247.

By Phone/Fax in the Europe

- Service is available from Axia Europe in Germany at +49 81 61 42 467. Fax: +49 81 61 42 402.

By E-Mail.

- The address is **Support@AxiaAudio.com**.

Via World Wide Web.

- The Axia Web site has a variety of information which may be useful for product selection and support. The URL is **<http://www.AxiaAudio.com>**.

Feedback

We welcome feedback on any aspect of Axia products or this manual. In the past, many good ideas from users have made their way into software revisions or new products. Please contact us with your comments.

Updates

The operation of the Axia node is determined largely by software. Periodic updates may become available - to determine if this is the case check our web site. Contact us to determine if a newer release is more suitable to your needs.

Our electronic newsletter has announcements of major software updates for existing products, as well as keeping you up to date on the latest Axia, Telos, and Omnia product releases. You may subscribe to update notifications here: <http://www.axiaaudio.com/signup.htm>

Trademarks

Telos Systems, Axia Audio, Livewire, the Livewire Logo, the Axia logo, SmartSurface, Element, SmartQ, Omnia, the Omnia logo, and the Telos logo, are trademarks of TLS Corporation. All other trademarks are the property of their respective holders.



Axia Audio

2101 Superior Ave. Cleveland, OH 44114 USA
+1 (216) 241-7225
Inquiry@AxiaAudio.com

Axia Europe

Johannisstra e 6, 85354 Freising, Germany
+49 81 61 42 467
Inquiry@AxiaAudio.com

Copyright © 2009 by TLS Corporation. Published by Axia Audio. We reserve the right to make improvements or changes in the products described in this manual, which may affect the product specifications, or to revise the manual without notice. All rights reserved.

Notice

All versions, claims of compatibility, trademarks, etc. of hardware and software products not made by Axia mentioned in this manual or accompanying material are informational only. Axia makes no endorsement of any particular product for any purpose, nor claims any responsibility for operation or accuracy.

Warranty

This product is covered by a five year limited warranty, the full text of which is included in the rear section of this manual.

Service

You must contact Axia before returning any equipment for factory service. Axia will issue a Return Authorization number, which must be written on the exterior of your shipping container. Please do not include cables or accessories unless specifically requested by the Technical Support Engineer at Axia. Be sure to adequately insure your shipment for its replacement value. Packages without proper authorization may be refused. US customers please contact Axia technical support at +1 (216) 241-7225. All other customers should contact their local representative to arrange for service.

We strongly recommend being near the unit when you call, so our Support Engineers can verify information about your configuration and the conditions under which the problem occurs. If the unit must return to Axia, we will need your serial number, located on the rear panel.

About This Manual

This manual covers the details of the Axia 8x8 Microphone, Analog and 8x8 AES nodes. However it is assumed in this document that you are familiar with Livewire's basic concepts, as outlined in the companion *Introduction to Livewire: System Design Reference & Primer* manual.

If you have not done so, please review that material first. In it we explain the ideas that motivated Livewire and how you can use and benefit from it, as well as nitty-gritty details about wiring, connectors, and the like. Since Livewire is built on standard networks, we also help you to understand general network engineering so that you have the full background for Livewire's fundamentals. After reading Introduction to Livewire you will know what's up when you are speaking with gear vendors and the network guys that are often hanging around radio stations these days.

As always, we welcome your suggestions for improvement. Contact Axia Audio with your comments:

Axia Audio, a Telos Company

2101 Superior Avenue

Cleveland Ohio 44114 USA

Phone: +1.216.241.7225

Web: www.AxiaAudio.com

E-Mail: Inquiry@AxiaAudio.com

Table of Contents

<i>Customer Service</i>	iii
<i>Warranty</i>	iv
<i>Service</i>	iv
<i>About This Manual</i>	iv
<i>A Note From The Founder/CEO of Telos</i>	vii
<i>A Note From The President of Axia</i>	viii

Chapter One: Introducing the Router Selector Node . 1

Description	1
Front Panel Controls and Indicators	1
<i>Fast Select Radio Buttons</i>	2
<i>LCD Display and Control Knob</i>	2
<i>Volume Control</i>	2
<i>Sync</i>	2
<i>Meters</i>	2
<i>Source Selection</i>	2
Rear Panel	2
<i>AC (Mains) Power</i>	2
<i>Livewire (100 Base-T) Connector</i>	2
<i>Input Connectors</i>	3
<i>Analog Line Input Characteristics</i>	3
<i>AES Input Characteristics</i>	3
<i>Output Connectors</i>	4
<i>Analog Output Characteristics</i>	4
<i>AES Input Characteristics</i>	4

Chapter Two: Operation via the Node's Front Panel . 5

Configuration & Testing	5
<i>Powering Up</i>	5
<i>Restoring Defaults</i>	5
<i>Bench Testing</i>	5
Basic Setup via the Front Panel	6
<i>Accessing The System Menu</i>	6
<i>Programming The Node's IP Configuration</i>	6
<i>Checking The Node Software Version</i>	6
<i>Setting The Node's Transmit Channel</i>	6
<i>Changing Main Output To Be Variable</i>	7
Operation	7
<i>Selecting A Stream For Playback</i>	7
<i>Assigning Streams To Radio Buttons</i>	7
<i>Adjusting Output Volume</i>	7

Chapter Three: Advanced Programming 9

Accessing the Node's Web Pages	9
<i>The Router Selector Home Page</i>	9
<i>Sources (Local Inputs)</i>	9
<i>Source Name and Channel</i>	9
<i>Shareable</i>	10
<i>Mode</i>	10
<i>Gain (dB)</i>	10
<i>AES Mode</i>	10
<i>Show Source Allocation Status</i>	11
<i>Destinations (Local Outputs)</i>	11
<i>Destination Name</i>	11
<i>Destination Channel</i>	11
<i>Destination Type</i>	11
<i>Output Load</i>	12
<i>Output Gain</i>	12
<i>Channel Filter</i>	12
<i>Meters</i>	12
<i>Sources</i>	13
<i>Destinations</i>	13
<i>System Parameters</i>	13
<i>IP Settings</i>	13
<i>Host name</i>	13
<i>Network address (IP Address)</i>	13
<i>Netmask (Subnet mask)</i>	13
<i>Gateway (Router)</i>	13
<i>Syslog Server (IP address)</i>	13
<i>Syslog severity level filter</i>	13
<i>User password</i>	14
<i>Firmware version</i>	14
<i>Saving Bank 1 Software</i>	14
<i>Downloading new software</i>	14
<i>Network & Quality of Service</i>	15
<i>Livewire Clock Master</i>	15
<i>Livewire Clock Mode</i>	15
<i>AES Synchronization and Clock</i>	15
<i>AES Sync Source</i>	16
<i>AES Mute on Livewire Fail</i>	16
<i>801.Ip tagging, 802.Ip VLAN ID, 802.1q Priority, &</i> <i>DSCP Class of Service</i>	16
<i>Receive Buffer Size</i>	17

Appendix A: Unbalanced Connections19

Appendix B: Axia Nodes and Ethernet Radios21

Appendix C: Troubleshooting.23

Appendix D: Specifications and Warranty.25

 Axia System Specifications25

 Axia Node Limited Warranty27

A Note From The Founder/CEO of Telos

It's been a tradition since Telos' very first product, the Telos 10 digital phone system, that I share a few words with you at the beginning of each manual. So here goes.

In radio broadcast studios we're still picking up the pieces that have fallen out from the digital audio revolution. We're not using cart machines anymore because PCs are so clearly a better way to store and play audio. We're replacing our analog mixing consoles with digital ones and routing audio digitally. But we're still using decades-old analog or primitive digital methods to connect our gear. Livewire has been developed by Telos to provide a modern PC and computer network-oriented way to connect and distribute professional audio around a broadcast studio facility.

Your question may be, "Why Telos? Don't you guys make phone stuff?" Yes, we certainly do. But we've always been attracted to new and better ways to make things happen in radio facilities. And we've always looked for opportunities to make networks of all kinds work for broadcasters. When DSP was first possible, we used it to fix the ages-old phone hybrid problem. It was the first use of DSP in radio broadcasting. When ISDN and MP3 first happened, we saw the possibility to make a truly useful codec. We were the first to license and use MP3 and the first to incorporate ISDN into a codec. We were active in the early days of internet audio, and the first to use MP3 on the internet. Inventing and adapting new technologies for broadcast is what we've always been about. And we've always been marrying audio with networks. It's been our passion right from the start. In our genes, if you will. As a pioneer in broadcast digital audio and DSP, we've grown an R&D team with a lot of creative guys who are open-eyed to new ideas. So it's actually quite natural that we would be playing marriage broker to computer networks and studio audio.

What you get from this is nearly as hot as a couple on their wedding night: On one RJ-45, two-way multiple audio channels, sophisticated control and data capability, and built-in computer compatibility. You can use Livewire as a simple sound card replacement – an audio interface connecting to a PC with an RJ-45 cable. But



add an Ethernet switch and more interfaces to build a system with as many inputs and outputs as you want.

Audio may be routed directly from interface to interface or to other PCs, so you now have an audio routing system that does everything a traditional "mainframe" audio router does – but at a lot lower cost and with a lot more capability. Add real-time mixing/processing engines and control surfaces and you have a modern studio facility with many advantages over the old ways of doing things. OK, maybe this is not as thrilling as a wedding night – perhaps kissing your first lover is a better analogy. (By the way, and way off-topic, did you know that the person you were kissing was 72.8% water?)

While we're on the subject of history... you've probably been soldering XLRs for a long time, so you feel a bit, shall we say, "attached" to them. We understand. But no problem – you'll be needing them for microphones for a long while, so your withdrawal symptoms won't be serious. But your facility already has plenty of Ethernet and plenty of computers, so you probably already know your way around an RJ-45 as well. It's really not that strange to imagine live audio flowing over computer networks, and there's little question that you are going to be seeing a lot of it in the coming years.

The 20th century was remarkable for its tremendous innovation in machines of all kinds: power generators, heating and air conditioning, cars, airplanes, factory automation, radio, TV, computers. At the dawn of the 21st, it's clear that the ongoing digitization and networking of text, audio, and images will be a main technology story for decades to come, and an exciting ride for those of us fortunate to be in the thick of it.

Speaking of years, it has been a lot of them since I wrote the Zephyr manual intro, and even more since the Telos 10 – 20 years now. Amazing thing is, with all the change around us, I'm still here and Telos is still growing in new ways. As, no doubt, are you and your stations.

Steve Church

A Note From The President of Axia

20 years ago, I designed my first broadcast console for PR&E. I look back on that time with great fondness; we were building bullet-proof boards for the world's most prestigious broadcasters, making each new console design bigger and fancier to accommodate a wider variety of source equipment and programming styles. The console was the core of the studio; all other equipment was on the periphery.

Then things changed: the PC found its way into broadcast audio delivery and production. At first, PC audio applications were simple, used only by budget stations to reduce operating expenses. But soon the applications evolved and were embraced by larger stations. Slowly, the PC was taking center stage in the radio studio.

Like many, I was captivated by the PC. Stations retired carts, phonographs, open-reel decks, cassettes — even more modern digital equipment such as DAT and CD players, replacing all with PC apps. Client/server systems emerged and entire facilities began using PCs to provide most — or all — of their recorded audio. Yet consoles continued to treat PCs as nothing more than audio peripherals. I knew that we console designers were going to have to re-think our designs to deal with computer-centric studios.

During this time, traditional broadcast console companies began producing digital versions. But early digital consoles were nearly identical in form and function to their analog predecessors. It took a fresh look from a European company outside broadcasting to merge two products — audio routing switchers and broadcast consoles — into a central processing engine and attached control surface. Eventually nearly every console and routing switcher company followed suit, and a wide variety of digital “engines” and control surfaces flooded the market.

But, advanced as these integrated systems were, they still handled computer-based audio sources like their analog ancestors. Sure, the router and console engine were now integrated, but the most important studio element — the PC — was stuck in the past, interfaced with 100-year-old analog technology. The PC and console couldn't communicate in a meaningful way — strange,

considering that PCs everywhere were being networked, fast becoming the world's most popular and powerful communication tool.

Then a group of Telos engineers developed a method of using Ethernet to network real-time audio devices, allowing computers and consoles, controllers and peripherals to interact smoothly and intelligently. Powerful, flexible networks had finally come to our studios. As with the transition from carts to computers, the benefits are many and impressive. A few networked components can replace routing switchers, consoles, processing peripherals, sound cards, distribution amps, selector switches and myriad related devices.

This deceptively simple networked system costs a fraction of other approaches, yet has capabilities surpassing anything else. The system is modular and can be used to perform discrete functions in a traditional environment. Concurrently, it easily scales to serve both the humblest and the very largest of facilities. Console, router, and computer work in harmony.

So, equipped with this new technology and countless ideas, we launch *Axia*, the newest division of Telos. *Axia* is all about delivering innovative networked audio products to future-minded broadcasters. On behalf of our entire team, I welcome you as a charter client. *Axia* is the culmination of nearly 40 man-years of some of the most ambitious R&D ever applied to the radio industry. And this is only the beginning. We have more products, innovations, and partnerships in the pipeline.

You already know your *Axia* system is unlike anything else. So it shouldn't be surprising that your new system is loaded with new thinking, new approaches, and new ideas in virtually every conceivable area. Some concepts will challenge your traditional ideas of studio audio systems, but we're certain that once you have experienced the pleasures of the networked studio, you'll never want to go back. And now, for something completely different...

Michael “Catfish” Dosch



Chapter One:

Introducing the Router Selector Node

This section will allow you to get to know the Router Selector Node and describes the unit's features, display, and connectors.

This manual is written with the assumption that you have read the *Introduction to Livewire – System Design Guide & Primer* document. While the Axia Livewire technology is easy to use in powerful ways, it does represent a radical new way of thinking for broadcasters. That document will serve to get your feet wet and to orient you. We highly recommend you review that document first, before building a Livewire audio system or reading this manual.

Description

The Axia Livewire Router Selector Node has one stereo input, and one stereo output. The user can feed audio into either a balanced analog input or an AES input.

The Router Selector node has both AES and analog balanced outputs. Both the AES and analog outputs are active simultaneously; both outputs have the same audio present.

Therefore, each Router Selector Node can create 1

stereo Livewire stream, which becomes available to other devices on the Livewire network.

Similarly, the node's stereo outputs can be assigned to output a single stereo Livewire stream acquired from the network.

The stream received can be easily selected from a list of available Livewire streams using the front panel. Eight frequently-used streams can be assigned to the front panel "radio buttons" for instant access.

A front panel headphone jack, LCD display, and control knob, round out the front panel. The control knob defaults to the headphone volume control function.

In addition to being a handy audio selector for use in the studio, the Router Selector node can be a handy Livewire tester/monitor node, for use in the Technical Operations Center or rack room.

NOTE: Only approved and properly programmed Ethernet switches incorporating the proper Multicast and QoS standards should be used. See www.AxiaAudio.com/switches/ for details.

Front Panel Controls and Indicators

The Livewire Router Selector Node incorporates a number of front panel controls to allow the operator to quickly and confidently select Livewire network audio sources for local playback. This section is an introduction to the node itself, for detailed operating information



Figure 1-1: Router Selector Node - Front Panel

consult Chapter 2.

Fast Select Radio Buttons

The 8 buttons on the left side of the node permit instant stream access. These work identically to the channel select buttons present on most radios. The built-in amber LED indicates that a particular button is active and the associated stream is being played. A label area above the buttons can be used to label the buttons, using commonly available thermal printed pressure sensitive labels (3/8 inch).

LCD Display and Control Knob

The built in LCD display and control knob permit most functions of the Router Selector node to be controlled from the front panel.

Volume Control

The control knob defaults to a volume control function for the built-in headphone jack and, optionally, the rear panel outputs. Turning the knob causes a volume indicator bar to be displayed showing the volume level setting. The volume indicator disappears three seconds after one ceases to change the volume.

Sync

The sync status is displayed in the upper right corner of the main LCD display. If sync packets are being received SYNC will begin to flash. SYNC will continue to flash until the local clock has locked to the network master. Once the local PLL is locked, SYNC will illuminate solidly. If the router selector is the network master then MASTER will be displayed.

Meters

The top section of the default LCD display shows the current Send (local input) and Receive (local output) levels for both left and right channels.

Source Selection

The control knob is also used to select the Livewire stream to be played. Briefly, clicking (e.g. depressing) on the control knob before rotating it puts it in stream selection mode. More on this later.

Rear Panel

The rear panel of the Router Selector node is pictured in Figure 1-3. The Router Selector node and RJ-45 connectors for inputs and outputs similar to the Analog and AES nodes. For your convenience, some XLR connectors are also provided.

AC (Mains) Power

The AC receptacle connects mains power to the unit with a standard IEC power cord. The power supply has a “universal” AC input, accepting a range from 90 to 240 VAC, 50-60 Hz. A fuse is located inside on the power supply circuit board

IMPORTANT! As with any piece of modern electronic gear, it is advisable that precautions be taken to prevent damage caused by power surges. Standard line surge protectors can be used to offer some degree of protection. It is the user’s responsibility to ensure protection adequate for their conditions is provided. This equipment is designed to be operated from a power source which includes a third “grounding” connection in addition to the power leads. Do not defeat this safety feature. In addition to creating a potentially hazardous situation, defeating this safety ground will prevent the internal line noise filter from functioning.

Livewire (100 Base-T) Connector

This connector is for connection to another Livewire node, or an approved Ethernet switch. It has two integral LEDs. The green “Link” LED indicates the presence of a live signal. The “Activity” LED indicates that Ethernet packets are being sent or received over the link.

IMPORTANT NOTE: Axia nodes are intended for use with an Ethernet Switch that supports multicast and QOS (Quality of Service). If you attempt to use them with non-switched Ethernet hubs, or a switch that is not enabled for multicast, you will experience network congestion that could disrupt other network activity.

Should you wish to connect a node to a non-Livewire network for access to the web configuration interface, etc, you must first confirm that streaming is disabled as described in Chapter 2.

Input Connectors

The node will automatically switch between analog and AES inputs; if a valid AES input signal is present, this will be used, otherwise the analog input will be used. Each analog stereo audio input is wired to an 8-position / 8-pin miniature modular jack (e.g. RJ-45 style) as well as two XLR female connectors. The AES input is wired to an 8-position / 8 – pin miniature modular jack as well as an XLR female connector. The RJ-45 connector pin functions are the same for both the AES and Analog and are as follows:

LINE and AES INPUT CONNECTORS	
Pin	Function: Analog/AES
1	Left Channel Input + /AES +
2	Left Channel Input - /AES -
3	Right Channel Input +
4	Not Connected
5	Not Connected
6	Right Channel Input -
7	Not Connected
8	Not Connected

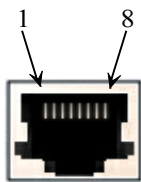

Figure 1-2: RJ-45 Pin Locations

IMPORTANT NOTE: Axia recommends using balanced audio for analog audio connections. If unbalanced sources are to be connected to these inputs, we strongly recommend using a balun (transformer) or balanced-to-unbalanced buffer amplifier at the source device. Such devices are readily available, for example the StudioHub “Match Jack”.

INPUT CONNECTORS (XLR-F)	
Pin	Function: Analog / AES
1	Ground
2	Balanced Input + / AES -
3	Balanced Input - / AES -

Analog Line Input Characteristics

- Connector – RJ-45 (Studio Hub+ compatible)
- Level (selectable)
- +4 dBu (+24 dBu clip point)
- +8 dBu (+26 dBu clip point)
- -10 dBV (+16 dBV clip point)
- Impedance – $\geq 10 K_{\Omega}$

AES Input Characteristics

- Connector – RJ-45 (Studio Hub+ compatible)
- Balanced 110 Ω (XLR)
- AES3/EBU Compliant

For additional technical information please see the Specifications section found at the end of this manual.



Figure 1-3: Router Selector Node - Rear Panel

Output Connectors

The stereo analog audio output is available on both an 8-position / 8 pin miniature modular jack (e.g. RJ-45 style) and a pair of XLR male connectors.

The AES output is also available on both an RJ-45 connector and an XLR male connector. The RJ-45 connector pin functions are the same for both the AES and Analog.

These outputs use the same pin designations as the inputs (see Figure 1-2 above).

Analog Output Characteristics

- Connector – RJ-45 (Studio Hub+ compatible)
- Level (selectable)
- +4 dBu (+24 dBu clip point)
- +8 dBu (+26 dBu clip point)
- -10 dBV (+16 dBV clip point)
- Impedance – < 50 _

AES Input Characteristics

- Connector – RJ-45 (Studio Hub+ compatible)
- Balanced 110 _ (XLR)
- AES3/EBU Compliant

What's Next

That's the "10,000-foot view" of the Router Selector Node. In Chapter 2, we'll learn how we can set up a brand-new Node out-of-the-box, without ever touching a PC! 🔄

Chapter Two:

Operation via the Router Node's Front Panel

In this chapter, we'll cover everything you need to get a new Router Selector node up and running using only the unit's front panel controls.

Configuration & Testing

Although all Axia Audio Nodes have built-in web servers for configuration and administration (whose use is covered in Chapter 3), you can set up basic node functions using only the front-panel controls — handy for those times when no PC is available. Note that many users will prefer to give the node an IP address using the front panel controls and then perform the rest of the configuration from the node's web pages.

Powering Up

When the Livewire Router Selector node is powered on you should observe the following: The eight Radio buttons should illuminate briefly, and after a short period of time the LCD display will illuminate and display the default screen (showing the meters and the stream currently selected).

Restoring Defaults

To restore the Livewire node to the default settings follow the steps below:

1. Power the node OFF.
2. Depress and hold the control knob.
3. Power ON the unit while continuing to hold the control knob.
4. After about 8 seconds, you will see “Hold knob for 3 Seconds to reset factory defaults” displayed. If you release the knob within 3 seconds, no changes will occur. If you continue to hold the knob, the default settings will be set and the screen will be go dark. At this time release the knob.

Bench Testing

Two Livewire Router Selector nodes may be connected together in “Point to point” mode (e.g. Ethernet snake mode) to verify operation of the units. When connected in this way the audio fed to “Audio Input” of “node A” will be output on “Audio Output” of “node B” whereas the audio on “Audio Input” of “node B” will be output on “Audio Output” of “node A”. To connect two units in “point to point” fashion follows these steps:

1. Restore default settings on both of the Livewire nodes to be connected. See “Restore Defaults”, above.
2. Set the TX channel as follows: Press the knob and hold until System Menu is displayed. Rotate the knob, if necessary, until Tx Channel is highlighted. Click the knob 5 times until the last digit of the entry to Tx Channel is highlighted. Rotate the knob clockwise until “1” is displayed (the entry for Tx Channel should now read 00001). Click the knob again to confirm your entry.
3. Enable streaming on each unit as follows: Rotate the knob till the word OFF is highlighted. Click the knob once to select this item, and then rotate it until SNAKE is displayed. Click the control knob to confirm your entry.
4. Rotate the control knob counter-clockwise until X is highlighted. Click the control knob to return to the default screen.
5. Connect the two units using a “Crossover 10/100 Base-T” Category 6 cable 100 meters maximum (see *Introduction to Livewire: System Design Reference & Primer*).
6. Click the knob to display the select streams display. Highlight SRC1 and click to select the stream.
7. Audio may now be fed into the input, and will be received on the corresponding output of the other unit. The receive (output) meters on each of the two units should show the audio from the far end.

NOTE: The above “Livewire Snake” mode of operation is the only case where to streams may share the same channel number. This is to minimize the steps to configure such a snake.

Basic Setup via the Front Panel

The main LCD screen is shown below:

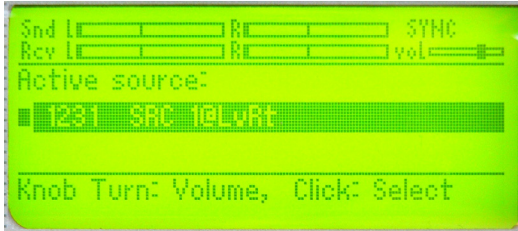

Figure 2-1: Router Selector Node - Default Screen

Basic programming of the Livewire Router Selector node can be accomplished using the front panel display and the control knob. The node's IP address, Transmit channel, and other information can also be checked from the front panel using the System Menu shown below.



Figure 2-2: Router Selector - System Menu

Accessing The System Menu

To access the system menu, press and hold the control knob from the default (meter) menu. To return to the main screen, rotate the control knob anti-clockwise until [X] is displayed and then press.

Programming The Node's IP Configuration

Each Livewire node must have a unique IP address. The only exception is when two nodes are connected in the point-to-point (snake) configuration.

To program the node's IP address follow these steps:

1. Starting from the metering screen, press and hold the control knob for 5 seconds. Once the System Menu is displayed turn the knob clockwise until IP Address is highlighted. The default IP address is
2. Click the control knob once. The first digit of the existing IP address will be highlighted. Rotate the control knob to set the first digit and then click to move to the next digit.
3. Continue until all digits of the IP address have been entered. After entering the last digit clicking will complete the entry process.
4. Make note of the IP address you have entered, so that you can access the Node using a Web browser, see Chapter 3.
5. The Subnet Mask (required) and Gateway IP address (optional) are entered in the same way as the IP address.
6. To return to the main screen, rotate the control knob anti-clockwise until [X] is displayed and then press.

“0.0.0.0”, so unless the unit has previously been programmed, the screen will show “000.000.000.000”.

Checking The Node Software Version

With the default meter screen displayed, press and hold the control knob for 5 seconds. The software version will be displayed in the top left corner of the System Menu.

Setting The Node's Transmit Channel

The Transmit Channel is the Livewire “channel number” assigned to the stream to be transmitted by this unit.

If you have read the *Introduction to Livewire: System Design Reference & Primer Manual*, you will know that each stream must have a unique channel number, so don't forget that now.

To program the node's Transmit Channel follow these steps:

1. Starting from the metering screen, press and hold the control knob for 5 seconds. Once the System Menu is displayed turn the knob clockwise until Tx Channel is highlighted. The default Tx Channel is “00000”, so unless the unit has previously been programmed, the screen will show this value.
2. Click the control knob once. The first digit of the existing Tx Channel will be highlighted. Rotate the control knob to set the first digit and then click to move to the next digit.

- Continue until all digits of the Tx Channel have been set. After entering the last digit clicking will complete the entry process.

Changing Main Output To Be Variable

By default, the line level output will be fixed and only adjustable from the web page. This can be changed using the front panel menu. Starting from the main screen, press and hold the control knob for 5 seconds. Once the System Menu is displayed turn the knob clockwise until **UOL Phone** is highlighted, then click to select. Rotated the knob to select **Ph&Out**, then click to select. Navigate to the **[X]** to exit the menu. Now the volume control on the front panel will control both the headphones and the line level outputs.

Operation

Operation of the Router Selector from the front panel is quite simple. Streams can be selected, assigned to an instant access Radio Button if desired, and the headphone/output volume may be adjusted.

Selecting A Stream For Playback

From the default menu screen click the control knob once. The source selection screen, shown below, will be displayed.



Figure 2-3: Router Selector - Source Selection

Rotate the control knob to highlight the desired Livewire stream and click to select it.

Streams can be displayed in order by their Livewire channel number, or by their Livewire name. To change the sort criteria rotate the knob clockwise until you reach the end of the source list. You can now highlight and

select from the following options:

- Name** – clicking this will cause the streams-list to be sorted by stream name.
- Chan** – clicking this will cause the streams-list to be sorted by stream Livewire channel number.
- Exit** – clicking this will return you to the default menu without selecting a new source.



Figure 2-3: Router Selector - Source List

Assigning Streams To Radio Buttons

Once a stream has been selected and is playing (e.g. by using the control knob and LCD display, see above), it can be assigned to any radio button by pressing and holding that button. After 5 seconds, the button's built-in lamp will blink indicating the new setting has been stored.

Adjusting Output Volume

Whenever the unit is at the default screen (the meters will be shown at the top of the screen) the headphone volume may be adjusted by rotating the control knob. By default, this adjusts the front-panel headphone levels only; the line level outputs on the rear panel are not affected unless the front panel level control has been configured for **Ph&Out** (headphones and output) as described in the previous Basic Setup section.

What's Next

You've learned the basic front-panel operation of Axia Audio Router Selector Node. In Chapter 3, we'll take a tour of the Router Selector Node Web Interface, where advanced options can be set to customize your Node. [🔗](#)

*In our youth we
never dreamed that, one day, streams
might not have water.*

Chapter Three:

Advanced Programming

This chapter will walk you through the use of the Router Selector Node's built in web pages to configure advanced features quickly, easily, — and remotely!

Accessing the Node's Web Pages

All of the node's parameters may be configured using the node's web configuration pages. To access the web server from a computer, the computer and node must be connected to the same LAN (or, the computer and Node can be connected using a "crossover 10/100 Base-T" Ethernet cable). To connect, open your web browser and enter the IP address of the node to be configured. Your browser should now display the node's home page, with links to the various functions available

A few things to remember: We assume you know the basics of network architecture, but we must mention that the first three numbers of the IP address of the computer you are using will normally match those of the Node you are attempting to configure; i.e., 192.168.15.xxx. If they don't, the gear won't be able to communicate and you'll just get frustrated.

Microsoft Internet Explorer 5 and later, and Mozilla Firefox 1.0 and later have been tested with Axia Audio Nodes. Other browsers may work, however they have not been tested.

Your browser must have the Java runtime library installed and enabled, and must allow "pop up" windows and display our meters. To obtain the Java runtime, visit www.java.com.

The Router Selector Home Page

The home page simply acts as a start page, to allow access to each of the configuration pages. We describe each of those pages in detail.

When you click on any link, you'll be prompted for a login and password. The default user name for all Axia nodes is "user". Other valid default user names (for nodes running current software) are "USER", "axia" and "AXIA". Leave the password field blank and click **OK**. Once you have successfully logged in, you may access any of the node's web pages.

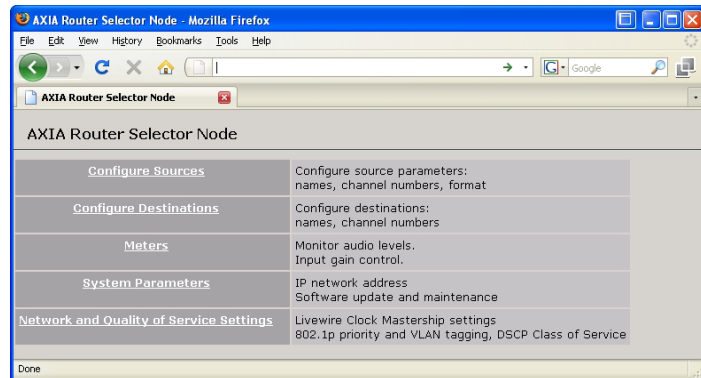

Figure 3-1: Router Selector Node - Home Page

Sources (Local Inputs)

This is where you configure the local input to this node, and assign a Livewire channels and parameters to that source. Once configuration is complete (or at any time in the configuration process) click on **Apply** to save your changes to the node.

Source Name and Channel

As described in the *Introduction to Livewire; System Design Reference & Primer* manual, each Livewire stream must be assigned a unique channel number. The

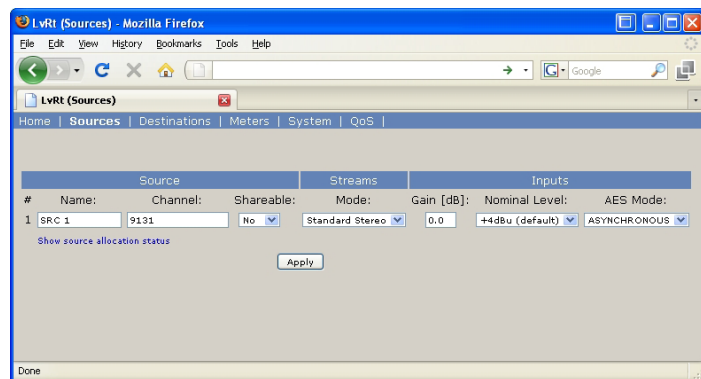

Figure 3-2: Router Selector Node - Sources Page

channel number must be a number between 1 and 32767.

Livewire names may contain any printable character or spaces and can be up to 24 characters long (when entering names excess characters will be truncated to 24 characters). Note however, that the displays on some Audio Nodes can display only 10 or 16 characters. In this case the left-most characters will be displayed, so keep this in mind.

You will want to develop a logical naming plan for your facility. For example you may wish to include the studio or rack name as part of your names to make life simpler when identifying sources in the future. We give some examples in the **Introduction to Livewire** manual.

Shareable

This is a feature provided for backward compatibility with SmartSurface consoles. This interlock prevents multiple consoles from sending simultaneous backfeeds or logic commands to a single source. A red lock indicates a console has locked the source and it is available to other consoles in listen-only mode.

Set all Node “Sharable” fields to “No” if you are using Element consoles running v2.0 or later software since the Element handles source sharing.

Mode

Sources for a Router Selector node can be Standard Stereo or Live Stereo. They can also be Enabled, or Disabled (we recommend leaving unused I/O Disabled to keep from generating empty audio streams).

- Standard Stereo – Generates a stereo source. This type is generally used for CD players, computers, and other common sources.
- Live Stereo – Generates a low latency stereo source. The type is generally used for microphones, phones, air monitors and other monitored “live” sources.
- Disabled – Audio source is disabled, no Livewire source stream is generated and no network bandwidth used.

Tip: Standard (Slow) streams conserve network bandwidth and are a better choice for delivering audio to computers for recording and playback.

Gain (dB)

This allows you to change the input gain in the digital domain. Care must be taken to ensure peak levels do not exceed 0 dBfs to prevent clipping. A gain range of up to +/- 12 dB may be selected in steps of 0.1 dB. Enter a value and click **apply** to make the change.

The analog line inputs clip point remains at +24 dBu so this level must not be exceeded. The rare device with a clip point in excess of +24 dBu will require an external pad.

The Gain setting may be used to adjust for differing peak output levels between different “+4 nominal” equipment, or it can be used to accommodate analog sources that are below +4 nominal levels.

- The default setting of 0 dB accommodates input levels at nominal levels of +4 dBu with a clip point of 24 dBu (e.g. 20 dB headroom). When feeding the node’s inputs from a “+4 nominal” device that clips at some lower level (for example +18 dBu, e.g. 14 dB headroom), you can adjust the gain (by 6 dB in our example) to match this device’s clip point to the node’s 0 dBfs point.
- This adjustment can also be used in cases where a low-level signal source must be used. Again you should use the rated clip point of the source device to determine the closest setting. Simply add gain to bring this rated clip point up to +24 dBu.

While we don’t usually recommend setting levels “by eye,” if you choose to do so, you can view the Source levels and adjust the Gain setting from the Meters page, see below.

AES Mode

There are two possible options for the setting:

- Asynchronous – this is the usual setting and enables sample rate conversion. Any valid AES source can be used in this mode without concerns about dropouts due to mismatched clocks.

- Synchronous – this setting can be used if the device transmitting the AES signal is synchronized to the Livewire network. For example, if the device synchronized its outputs to its input, and the input were fed from an Axia AES node or, if the device had a Sync input fed from an Axia AES node. Enabling the Synchronous mode turns off sample rate conversion thereby reducing latency. This is perfect for use with digital microphones or for “purist” applications.

Show Source Allocation Status

Click on this link to display the console and fader to which the source(s) on this node are assigned. This is helpful when tracking down a source that’s reported as being “locked” (non-sharable).

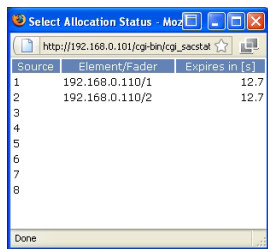

Figure 3-3: Source Allocation Pop-Up

Destinations (Local Outputs)

The page permits entering information related to this node’s local output. Node outputs are always destinations to which Livewire audio streams are delivered. You can name these outputs and select the stream to be delivered to each output. The Destinations screen for the Router Selector node is shown in Figure 3-4.

Destination Name

This is the name used to identify this destination (local output) within the Livewire network. While these names are optional, we encourage you use them to describe what is wired to the node output.

Destination Channel

These are the Livewire channels to be routed to each local output. If the channel

to be output is not yet available on the network, you can manually enter the channel number here. In the usual case you can click on the **choose channel** button to the right of this field, and a Select Source screen will be displayed similar to the one shown in Figure 3-5.

You can now click on the name or channel number of the desired source to assign it to this Destination (local output).

Destination Type

There are two choices for this setting. Let’s take a look at each one.

- From Source: Stereo output of the same type, Live or Standard, as the source.
- To Source: Backfed to a bidirectional audio source such as a phone or codec.

We have used the term **Backfeed** in our discussion above. Let us regress for a moment and review backfeeds. You will recall from the *Introduction to Livewire; System Design Reference & Primer* manual that Livewire permits special bidirectional streams for use with cases where a source and destination are associated, such as a codec or phone hybrid. The return feed to such devices is usually a mix-minus (backfeed) generated by a mix engine fed back to the device that is the primary audio source (and usually the name of the stream in question). In effect you have thus created a bidirectional Livewire channel with a single channel number.

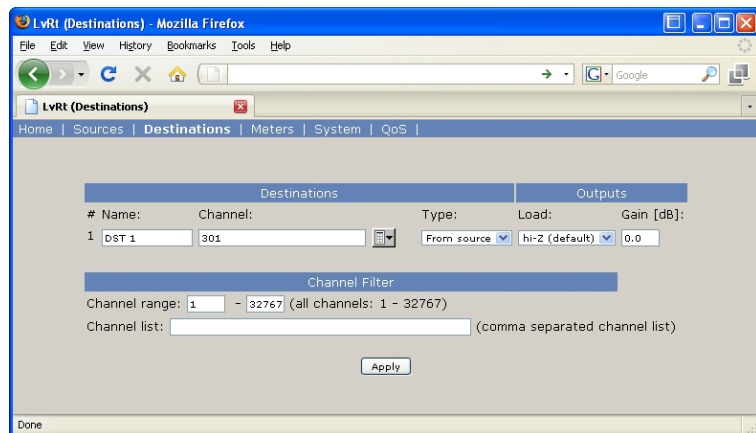

Figure 3-4: Router Selector Node - Destinations Page

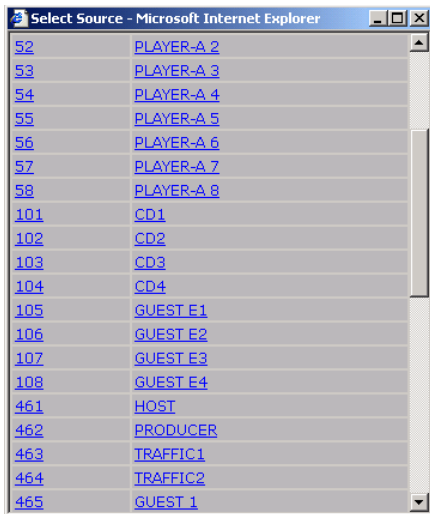

Figure 3-5: Node - Destinations Pop-up.

What does this all mean in practice? If the destination is a codec or hybrid you'll set the Destination Type to **To Source** and use the same Channel number as the stream representing the Codec or Hybrids output (the caller or far end codec audio).

Output Load

This setting has two options. The usual selection is Hi-Z and is used when the node's outputs are fed to High impedance destination devices. If the node is feeding 600 Ohm inputs (very rare these days) the 600 ohm option should be selected. This boosts the node's output level by ~1 dB to maintain true +4 levels into 600 Ohm equipment to ensure unity gain. The clip point remains at 24 dB.

Output Gain

An output gain control is provided to make adjustments that may be required if external equipment needs a level other than +4dB. Signal level throughout an Axia system should be +4dB since we know you will have normalized these levels by adjusting source gain

if necessary. The range of the output gain is +/- 12 dB. This adjustment is commonly used for connections to consumer-grade or other equipment that may have unusual signal levels.

Channel Filter

Use this to reduce or filter what sources can be viewed from the front panel but not the web page. Only the channel numbers listed are available and either a range or a comma delimited list can be used. Any channels that are the list must also be included in the range. The list is not in addition to the range - the list is the only ones that will be displayed. Example: If the channel range is set to 1-100 and the channel list includes only 90, then only source 90 will be displayed. If the range is set from 1-32767 and the channel list is 1-100, 125, then all channels from 1 to 100 and 125 will be displayed. If no filtering is desired, set the range to 1 - 32767 and leave the list blank. Click apply to make the change

Meters

The Meters screen, shown in Figure 3-6, is a metering screen that shows the audio level of the local source (local input) and destination (local output) for the node. The screen is divided into two sections, with the input

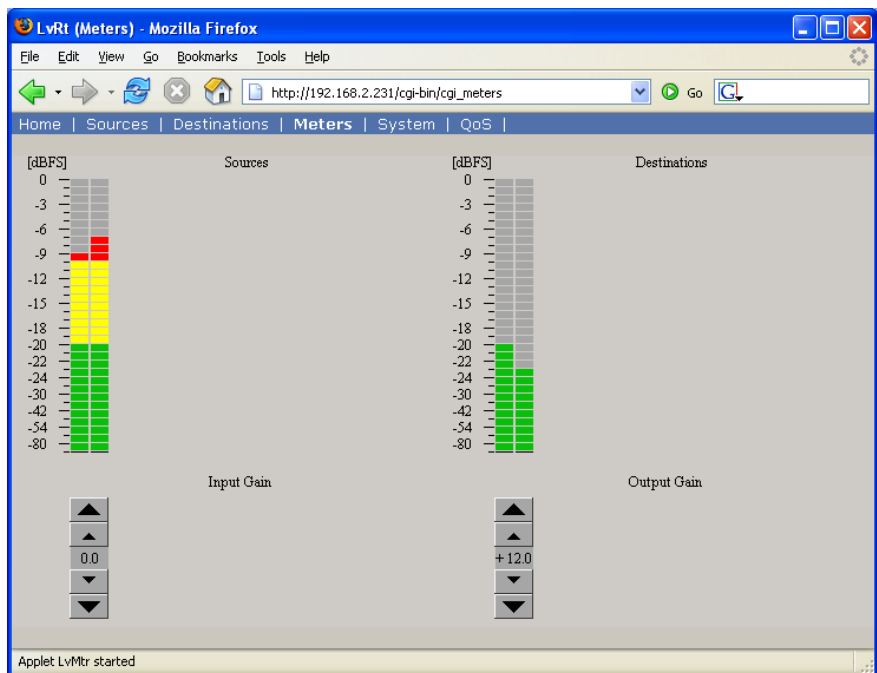

Figure 3-6: Router Selector Node - Meters Page

on the left and the output on the right. Each section has a display, with a left and right meter for each input or output. Note that the levels shown are in the digital domain, and are therefore calibrated in dBfs. The color-coding of the meters is somewhat arbitrary; the meters turn red approximately 9 dB before the clip point (e.g. 9 dB below digital full scale) but this does not represent an overload condition.

NOTE: If the meters are not displayed, Java needs to be installed on the computer. Java is a free download and may be obtained from www.java.com.

Sources

While we recommend setting the gain setting for inputs based on the peak output clip point of the source equipment (see Source Page, above), you can use the meter screen to tweak input Gain settings “by eye” if desired. Use the large arrows to adjust the level by 1 dB, use the small arrows to adjust the level by .1 dB.

Destinations

This meter represents the Livewire stream being output from this node. These meters are primarily for confidence monitoring. As with the front panel, the lower-most segment indicates that the designated Livewire stream is present, even if no audio is currently playing. Use the large arrows to adjust the level by 1 dB, use the small arrows to adjust the level by .1 dB.

System Parameters

The System Parameters page, shown in Figure 3-7, allows configuring the node’s IP address and related settings. It also permits choosing between a primary and secondary bank of software and to download new software into the secondary bank. The currently running software version is displayed here as well. You must click the **Apply** button for changes to take place.

IP Settings

These are the usual IP-related settings (see *Introduction to Livewire; System Design Reference & Primer* for an overview and some good references to additional information). Your network administrator should be able to provide the needed values. Each unit must have a

unique IP address.

Host name

The name is a 12-character, alphanumeric name for this Node that may include hyphens but NOT spaces; those will be converted to hyphens. This name is used to identify the node on the network. You may wish to include the location of the node (studio or rack) in the name for ease of reference.

Network address (IP Address)

The IP address of the node. Each Audio Node must have a unique IP address. The only exception is when two nodes are connected in the point-to-point (snake) configuration. Normally this would be set using the front panel, but it can be checked or changed from this web page, if needed.

NOTE: If you change the IP address you will lose your browser connection when you click Apply, and will need to reconnect using the new IP address.

Netmask (Subnet mask)

This is the IP subnet mask of the local unit. The typical setting that is suitable for most cases is 255.255.255.0.

Gateway (Router)

This may be the IP address of the IP Router connecting the local IP network with some other IP network. This is not used or required in most cases.

Syslog Server (IP address)

Various services generate syslog (RFC 3164) messages, which can be forwarded to a remote syslog daemon. The remote syslog daemon IP address can be entered on the System WEB page.

Syslog severity level filter

You can customize syslog logging by choosing log detail level:

- Emergency: system is unusable
- Alert: action must be taken immediately
- Critical: critical condition
- Error: error conditions
- Warning: warning conditions

- Notice: normal but significant condition
- Informational: informational messages
- Debug: debug-level message
- Only messages with a severity higher than that specified by the filter will be forwarded to the remote logger.

User password

This is the password required to connect to the unit. It must be at least 5 characters long and may be as long as 8 characters. Only alphanumeric characters are permitted. To change the password you must enter the new and old passwords and then click Apply. NOTE: If you changed the IP or Firmware settings the unit will reboot. If you have only entered a new password the unit will not reboot.

IMPORTANT! Changing device passwords can have serious implications on the operation of you Pathfinder software. Consult the Pathfinder manual before making changes to your password scheme.

When logging into the node any of the following “user names” may be used: user, USER, axia, Axia, AXIA. The default password is blank for any of the above users.

Firmware version

An Axia node has two internal memory “banks”. Each bank contains room for a complete version of operating software. This approach allows a software update to be completed and checked without danger of making the unit inoperable if the download were to be incomplete or corrupted. It also provides an easy way to try a new software version and still return to the old version.

The software version in each bank is displayed here. To change banks simply click in the “radio button” for

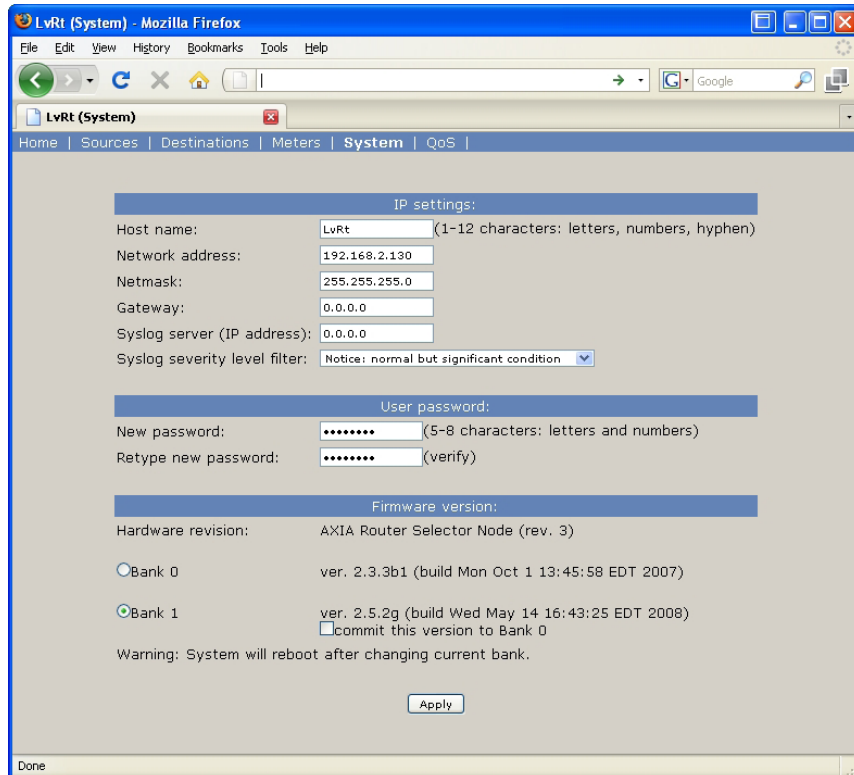

Figure 3-7: Router Selector Node - System Page

the desired bank and then click on **Apply**.

IMPORTANT! The node will reboot after you click Apply if you change the software version. This will result in loss of audio locally, and at any unit using the local sources of this node.

Saving Bank 1 Software

Software is always downloaded to bank 1 (the secondary bank). Downloading new software to your node (see below) will overwrite any software currently in this bank. If you wish to save the software currently in bank 1, you can save it by moving it to bank 0 as follows:

- Click on **Commit this version to Bank 0** box (see Figure 3-8).
- Click on **Apply**.

Downloading new software

A new version of software can be downloaded into bank 1 as follows:

1. Go to the Axia web site www.axiaaudio.com/downloads/ and download the desired software update

for your node to your computer (this should be the computer that you will use to access the node's web page). Your local computer operating system should display a prompt to permit you to choose where you wish to locate the downloaded file. You can choose any convenient location, just be sure to note the drive and location where the file is to be saved.

2. Open a web browser and connect to the node to be updated. Enter the complete path and file name for the software file (e.g. the file downloaded from the Axia site), or click on the Browse button to locate the file. Once the proper path and filename are displayed, click on **Apply** to download the file.
3. A successful download will be indicated by the new version being displayed in the Bank 1 field. If the download is unsuccessful the field for Bank 1 will be blank.
4. To run the new software click on Bank 1 radio button and then click on **Apply** to reboot the node. It will take approximately 20-30 seconds for the node to reboot.

IMPORTANT! The node will reboot after you click Apply when changing between software versions. This will result in loss of audio locally, and at any unit using the local sources.

Network & Quality of Service

The Router Selector Node node QoS page is shown in Figure 3-8. The settings on this screen are advanced settings, and generally the default settings should be used.

Livewire Clock Master

Livewire's clocking system is automatic and largely transparent to end users. By default, the Axia hardware node with the lowest Ethernet IP address will be the clock "master". The system will automatically and transparently switch to a new unit as clock master if needed. We do however, permit you to force clock mastership to a particular node or set certain nodes as "preferred" for clock mastership while maintaining automatic operation. For example you may prefer to have nodes that are on UPS power be preferred clock masters. Note that in the automatic modes clock mastership is changed only when

the current master becomes unavailable (adding a new node will not change clock mastership regardless of the new node's setting). The only exception is the 7 (Always Master) setting.

You have the following choices for this setting:

- 0 (always slave) "STL" – Unit will never be master and is only used with Ethernet radios.
- 0 (always slave) – This unit will never be used as clock master.
- 3 (default) – The usual setting.
- 4 (Secondary Master) – Nodes with this setting will be used as clock masters before those set to 3.
- 5 (Primary Master) – Nodes set to this setting will be used as clock masters before those set to 4.
- 7 (Always Master) – This forces a particular node to be clock master, even if another node is currently clock master. If this mode becomes available then the usual prioritization is used.
- 7 (Always Master) "STL Snake" – This forces a particular node to be clock master. Use only when two nodes are connected back to back without an Ethernet Switch.

IMPORTANT! Only a single node on a Livewire network should ever be set to 7 (Always Master). For this reason we do not recommend using that selection.

Livewire Clock Mode

Provided for compatibility with older revisions:

- IP low rate (default) – recommended setting
- Ethernet – compatible with 1.x firmware
- IP High rate – compatible with 2.1.x master

AES Synchronization and Clock

These settings determine two factors. The Livewire Clock Master Priority setting determines the clock mastership options as described above for the Router Selector Node.

The AES functions of the node also permit additional synchronization options to lock the node to an AES source, as discussed below.

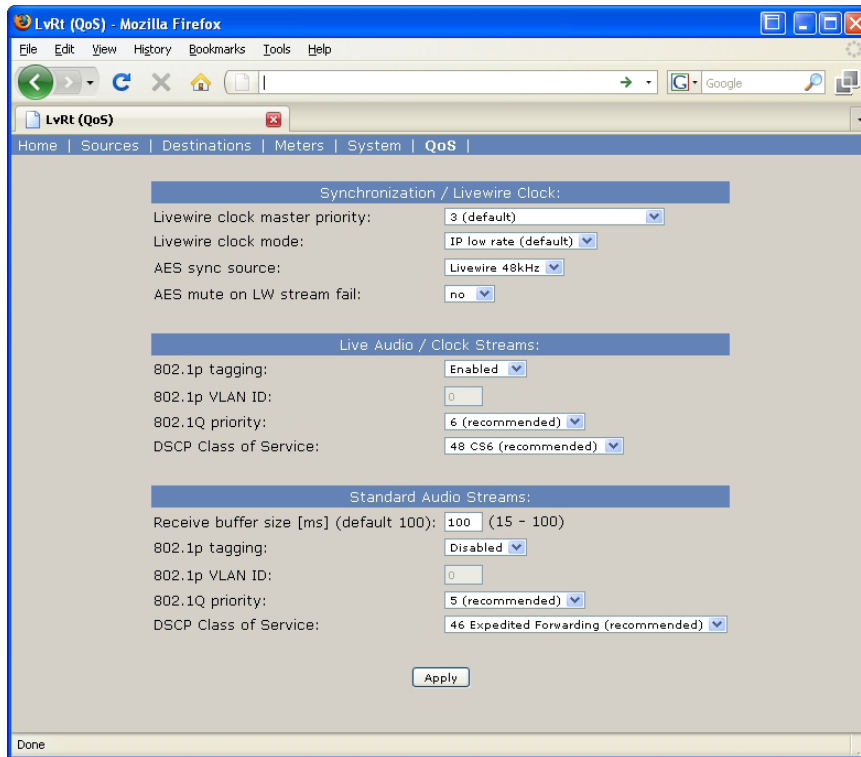

Figure 3-8: Router Selector Node - QoS Page

Livewire Master clock.

AES Mute on Livewire Fail

This option may be set to **Yes** or **No**. The function is rather self-explanatory. When set to **Yes**, the AES audio output will be muted should there be a Livewire sync failure or loss of Livewire stream.

801.1p tagging, 802.1p VLAN ID, 802.1q Priority, & DSCP Class of Service

802.1p tagging is necessary within the Livewire network to mark high-priority audio packets. This information is used by the Ethernet switches in the packet scheduling and queuing mechanism. It provides low-jitter packet forwarding of Livewire clock and low-latency audio streams.

AES Sync Source

There are three settings for AES Sync Source:

- Livewire 48kHz
- AES Sync
- AES Input

If AES sync source is set to **Livewire 48 kHz** then the system will simply use the unit's internal clock source if and when it becomes clock master. This is the most common setting for a Router Selector node

Setting the Sync Source to **AES Sync** will use the rear panel RJ-45 connector that is labelled AES IN/SYNC as a clock reference for the local Router Selector node.

Setting the Sync Source to **AES Source** will use the rear panel XLR connector that is labelled AES IN (the AES audio input) as a clock reference.

Note that unlike an Axia 8x8 AES node, a Router Selector node cannot function as an AES sync source for

On the other hand, Standard streams don't need tagging, because they are not low-latency. By default, standard streams are marked with Type of Service (DSCP code points) information in the IP header which can be used by L3 switches to provide better service to our audio streams than to best effort IP traffic.

There is an option to enable L2 802.1p tagging on standard streams, and this may be used with switches which do not use the DSCP information included in the TOS field of the IP header. We do not enable this tagging by default, because it wouldn't work in cross-over Ethernet connection to PCs; most network cards do not accept 802.1p frames by default.

You should not need to change these default settings unless you are building a system which is not based on our recommendations.

In Axia nodes, the VLAN ID setting is read-only. It is always 0 and cannot be changed. As a result Livewire audio always uses the native VLAN assigned to the port

of the switch.

“DSCP Class of Service” is a standard describing the tagging of IP frames with service information. Network equipment can be set up to provide different forwarding delay and drop precedence depending on the service information. Our defaults are compatible with most Ethernet equipment defaults for class of service Livewire requires; you should not need to change them unless instructed by Axia Support.

Receive Buffer Size

Determines the amount of buffering in the receiver when receiving Standard Streams. Buffering is needed to compensate for jitter in network packet delivery. Usually the biggest source of the jitter is a source PC. Real-time performance varies widely from one system to another; some computers can provide very low timing irregularities and allow the receive buffer to be reduced to achieve lower audio delay. The default setting is 100 ms.

*Isn't it time you
finally threw out all of
those dusty scotchCarts?*

Appendix A: Unbalanced Connections

We've told you, both earlier in this manual, and in *Introduction to Livewire; System Design Reference & Primer*, that Axia recommends balanced audio connections when connecting analog source and destination gear to the inputs and outputs, respectively, of Axia nodes. Not only do we recommend this for the usual reasons, but because inter-channel crosstalk between the left and right channels of unbalanced signals sharing the same Cat. 5 cable is a possibility. As we've mentioned before, we recommend converting between balanced and unbalanced at the unbalanced device and then using the standard Cat. 5 connection from there to the Axia node.

There are a number of active balanced-to-unbalanced and unbalanced-to-balanced adaptors commercially available at a reasonable cost (see www.studiohub.com for a pair of units that will easily plug and play with our gear). We'll suggest one more time that this approach is the way to go, and that using unbalanced cable runs will compromise the performance of your state of the art Axia audio network. However, if you are in a bind, or otherwise determined to do so, here is how we recommend connecting Axia nodes to unbalanced equipment:

Unbalanced Destinations

To feed audio to an unbalanced destination from the 8x8 Analog node you must use a separate cable for the left and right signals, and you will need a shielded RJ-45 plug so you can terminate the shield of the audio cables. RJ-45 Pin 1 will feed the Left signal with the signal common (e.g. cable shield) connected to the RJ-45 shield. Pin 3 will feed the Right signal with the signal common (e.g. cable shield) connected to the RJ-45 shield.

An external pad may be required if the destination equipment's inputs cannot accept signals with peak levels of +24 dBu.

Generally the unused output pin should not be tied to

the shield. Doing so will not harm the node, however doing so will activate a feature that will increase the output level by 6 dB, which is generally not desirable.

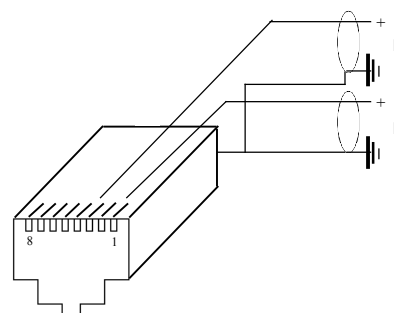

Feeding unbalanced device inputs from Axia 8x8 analog node outputs.

Unbalanced Sources

To feed an unbalanced signal from a source into the inputs of the analog 8x8 node you must use a separate cable for the left and right signals. We generally prefer the method where the unbalanced signal is presented across the differential balanced inputs of the node. The handling of the shield will depend on the equipment and grounding practices used.

If both pieces of equipment are grounded to a facility grounding system then the shield may be left open at one end (or both ends), as follows.

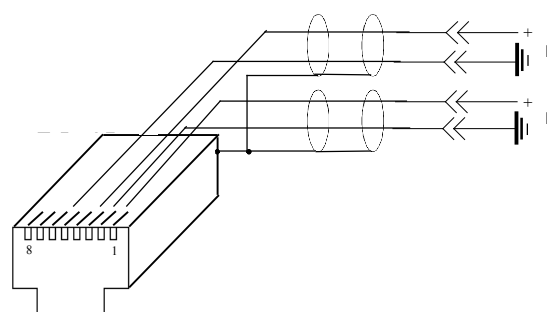

Axia node's analog inputs fed from an unbalanced source where both pieces of equipment are tied to a facility ground.

Alternatively, if both pieces of equipment are not both tied to a common facility ground, both sides of the shield must be connected. In this case the “-“ side of the nodes inputs are tied to the shield of the RJ-45 plug as follows:

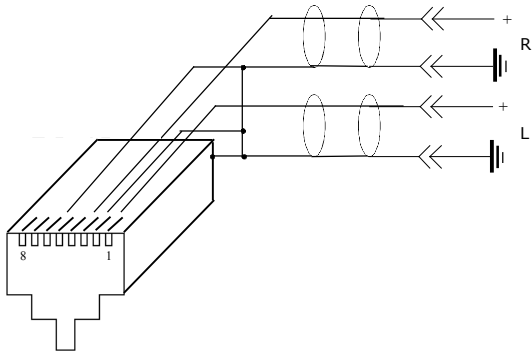

Axia node's inputs fed from a floating source, with no facility ground in common with the Axia node.

Appendix B: Axia Nodes and Ethernet Radios

This tech note applies to Node Software v2.3.2a and higher

There are several changes and additions to Axia Audio Nodes software beginning with v2.3.2a designed to simplify the operation of STLs and audio snakes using Axia nodes in conjunction with Ethernet Radios.

These additions include:

- STL Slave and STL Snake modes on Clock Master Priority options
- IP Low Rate is now set as the default receive Clock mode in the LW Clock Mode options field. (Note that this setting only defines the RECEIVE type of stream. It does not change the clock stream type when the node is acting as the Master Clock. We recommend that you do not change this setting.)
- A Standard Stream Buffering option, which is set to 100ms as default. (Note that this setting should not be adjusted unless advised otherwise by Axia Technical Support.)
- A “Master/Sync” confidence tally is added to the Router Selector Node display.

Note that the setup options described below require that Node Software v2.3.2a or higher must be installed to work correctly.

Using two nodes back to back without an Ethernet switch

In this scenario, the clock sync mode will set the Clock Rate to a Low Rate sync packet regardless of the Livewire Clock Mode setting. This enables a more stable SYNC mode, eliminating the need for an Ethernet switch between the nodes handling QOS of the clock sync signal.

Navigate to the “QOS” web pages of the Audio Nodes you’ll be using. Determine which one will be the master and which the slave, and set the new “STL Snake” and “STL Slave” clock priority modes to the appropriate values.

Typically, you will set the Clock Master Priority option on the Node located in the studio to “7 (Always Master) STL Snake”. The Node on the remote end of the link should be set to “0 - (Always Slave) STL”.

All stream types must be set to Standard streams. Leave Standard Stream buffering at 100ms (the default setting).

Connecting a “remote” Audio Node to an existing Axia network using Ethernet Radio

If you are using Studio Engines and/or existing nodes connected to an Ethernet switch, then these instructions assume that you have a current Livewire Network and are adding a node at a remote location connected via an IP radio. You must maintain the high rate Master clock sync packets for these devices in order for all nodes to sync properly. This is especially important for the well-being of the Axia Studio Mix Engines.

In this case, you will need to have at least ONE Audio Node on the main Livewire network designated as the MASTER CLOCK and running version 2.3.2a software. It should be set to a higher priority than all other nodes running earlier software versions. We recommend choosing “7 - (Always Master)”. Do not select “7 - (Always Master) STL Snake” for this application.

The remote node at the receive end of the Ethernet radio should likewise be running v2.3.2a or newer software. Its clock setting should be “0 - (Always Slave) STL”.

Deep Tech: A node running version 2.2.0, when op-

erating as the current Clock Master, will generate two clock streams: a High rate and a Low rate clock sync. Nodes running version 2.1.x and earlier do not have this dual clock feature and require the High rate sync to operate as well.

Streams sent to the “remote” node should all be STANDARD streams. Leave Standard Stream buffering at 100ms (the default setting) on the receiving node.

IP Radio Settings and Recommendations

Settings on your Ethernet radios will have to be tweaked as needed. Unfortunately, due to the large number of Ethernet radios on the market, at the rate at which these products change, we are unable to make specific recommendations on which radio to choose, or their exact optimal settings.

Some Quality of Service options may assist or hinder the operation of the radio for multicast UDP data packets. This may involve turning ON or OFF some or all the “smarts” within the radio. User experience will differ from model to model. We suggest that you contact your radio’s manufacturer for additional support on the operation of the radios in this mode. For the purposes of passing Livewire streams reliably, we desire that the IP radios behave as much as possible like a simple piece of CAT6 cable, with minimal latency.

Questions on the operation of the Axia Audio Nodes can be emailed to Axia support at support@axiaaudio.com.

Appendix C: Troubleshooting

Here are some basic troubleshooting tips that might prove useful. Don't forget that the *Introduction to Livewire; System Design Reference & Primer* should be your companion and has many useful tips. Our on-line forum also contains tips from users as well as our own Tech Tips section found at <http://forums.axiaaudio.com>

Problem	Possible Solution
SYNC indicator on front panel is not displayed.	<p>This indicates that the node is not able to lock onto a clock source. This is because there is no master clock or a network problem (not properly configured network switch)</p> <ul style="list-style-type: none"> • check Ethernet switch configuration • verify that there is a node assigned a “clock priority” value greater than 0 on the network
No Meters are displayed on the “meters” http page.	<p>This page require Java be installed on the PC being used to display the node's web pages. Java is a free download from www.java.com.</p>
Audio from a node sounds bad. The meters on the web page show audio. The meters on the front display are not present.	<ul style="list-style-type: none"> • This indicates a problem with the source packet. This can be due to two devices producing data on the same multicast channel (source channel number) or also could be due to network problems. If the data is passing through a trunk cable that is heavily used (a lot of data, over 50%) data could be getting dropped. Note that the meters on the front display will show activity if the data is valid. The meters on the web page may show activity, but this does not show valid data is actually being received. • Sometimes, on a small network, you may get output from a node but it has drop-outs and is just not “quite right”. Check the clock (master/sync) to make sure your node is getting or generating Livewire clock. See item on sync above.
Need to reset node to factory defaults.	<ol style="list-style-type: none"> 1. Power the node OFF. 2. Depress and hold the front panel control knob. 3. Power ON the unit while continuing to hold the control knob. 4. After about 8 seconds will see the word “RESET 3 S” displayed. If you release the control knob within 3 seconds no changes will occur. If you continue to hold the control knob, in 3 seconds the default settings will be set and “REBOOT” will be displayed. At this time release the control knob.

World, now digital

Analog memories fade.

The future beckons!

Appendix D: Specifications and Warranty

Axia System Specifications

Microphone Preamplifiers

- Source Impedance: 150 ohms
- Input Impedance: 4 k ohms minimum, balanced
- Nominal Level Range: Adjustable, -75 dBu to -20 dBu
- Input Headroom: >20 dB above nominal input
- Output Level: +4 dBu, nominal

Analog Line Inputs

- Input Impedance: >40 k ohms, balanced
- Nominal Level Range: Selectable, +4 dBu or -10dBv
- Input Headroom: 20 dB above nominal input

Analog Line Outputs

- Output Source Impedance: <50 ohms balanced
- Output Load Impedance: 600 ohms, minimum
- Nominal Output Level: +4 dBu
- Maximum Output Level: +24 dBu

Digital Audio Inputs and Outputs

- Reference Level: +4 dBu (-20 dB FSD)
- Impedance: 110 Ohm, balanced (XLR)
- Signal Format: AES-3 (AES/EBU)
- AES-3 Input Compliance: 24-bit with selectable sample rate conversion, 32 kHz to 96kHz input sample rate capable.
- AES-3 Output Compliance: 24-bit
- Digital Reference: Internal (network timebase) or external reference 48 kHz, +/- 2 ppm
- Internal Sampling Rate: 48 kHz
- Output Sample Rate: 44.1 kHz or 48 kHz
- A/D Conversions: 24-bit, Delta-Sigma, 256x oversampling
- D/A Conversions: 24-bit, Delta-Sigma, 256x oversampling
- Latency <3 ms, mic in to monitor out, including network and processor loop

Frequency Response

- Any input to any output: +0.5 / -0.5 dB, 20 Hz to 20 kHz

Dynamic Range

- Analog Input to Analog Output: 102 dB referenced to 0 dBFS, 105 dB “A” weighted to 0 dBFS
- Analog Input to Digital Output: 105 dB referenced to 0 dBFS
- Digital Input to Analog Output: 103 dB referenced to 0 dBFS, 106 dB “A” weighted

- Digital Input to Digital Output: 138 dB

Equivalent Input Noise

- Microphone Preamp: -128 dBu, 150 ohm source, reference -50 dBu input level

Total Harmonic Distortion + Noise

- Mic Pre Input to Analog Line Output: <0.005%, 1 kHz, -38 dBu input, +18 dBu output
- Analog Input to Analog Output: <0.008%, 1 kHz, +18 dBu input, +18 dBu output
- Digital Input to Digital Output: <0.0003%, 1 kHz, -20 dBFS
- Digital Input to Analog Output: <0.005%, 1 kHz, -6 dBFS input, +18 dBu output

Crosstalk Isolation and Stereo Separation and CMRR

- Analog Line channel to channel isolation: 90 dB isolation minimum, 20 Hz to 20 kHz
- Microphone channel to channel isolation: 80 dB isolation minimum, 20 Hz to 20 kHz
- Analog Line Stereo separation: 85 dB isolation minimum, 20Hz to 20 kHz
- Analog Line Input CMRR: >60 dB, 20 Hz to 20 kHz
- Microphone Input CMRR: >55 dB, 20 Hz to 20 kHz

Power Supply AC Input

- Auto-sensing supply, 90VAC to 240VAC, 50 Hz to 60 Hz, IEC receptacle, internal fuse
- Power consumption: 35 Watts

Operating Temperatures

- -10 degree C to +40 degree C, <90% humidity, no condensation

Dimensions and Weight

- Microphone node: 1.75 inches x 17 inches x 10 inches, 6 pounds
- Analog Line node: 1.75 inches x 17 inches x 10 inches, 6 pounds
- AES/EBU node: 1.75 inches x 17 inches x 10 inches, 6 pounds
- Router Selector node: 1.75 inches x 17 inches x 10 inches, 6 pounds
- GPIO node: 1.75 inches x 17 inches x 13 inches, 8 pounds
- Studio Mix Engine 3.5 inches x 17 inches x 15 inches, 10 pounds

Axia Node Limited Warranty

This Warranty covers “the Products,” which are defined as the various audio equipment, parts, software and accessories manufactured, sold and/or distributed by TLS Corp., d/b/a Axia Audio (hereinafter “Axia Audio”).

With the exception of software-only items, the Products are warranted to be free from defects in material and workmanship for a period of five (5) years from the date of receipt by the end-user. Software-only items are warranted to be free from defects in material and workmanship for a period of 90 days from the date of receipt by the end-user.

This warranty is void if the Product is subject to Acts of God, including (without limitation) lightning; improper installation or misuse, including (without limitation) the failure to use telephone and power line surge protection devices; accident; neglect or damage.

EXCEPT FOR THE ABOVE-STATED WARRANTY, AXIA AUDIO MAKES NO WARRANTIES, EXPRESS OR IMPLIED (INCLUDING IMPLIED WARRANTIES OF MERCHANTABILITY AND FITNESS FOR A PARTICULAR PURPOSE).

In no event will Axia Audio, its employees, agents or authorized dealers be liable for incidental or consequential damages, or for loss, damage, or expense directly or indirectly arising from the use of any Product or the inability to use any Product either separately or in combination with other equipment or materials, or from any other cause.

In order to invoke this Warranty, notice of a warranty claim must be received by Axia Audio within the above-stated warranty period and warranty coverage must be authorized by Axia Audio. If Axia Audio authorizes the performance of warranty service, the defective Product must be delivered, shipping prepaid, to: Axia Audio, 2101 Superior Avenue, Cleveland, Ohio 44114.

Axia Audio at its option will either repair or replace the Product and such action shall be the full extent of Axia Audio’s obligation under this Warranty. After the Product is repaired or replaced, Axia Audio will return it to the party that sent the Product and Axia Audio will pay for the cost of shipping.

Axia Audio’s authorized dealers are not authorized to assume for Axia Audio any additional obligations or liabilities in connection with the dealers’ sale of the Products.

Axia Audio’s products are to be used with registered protective interface devices which satisfy regulatory requirements in their country of use.

#1490-00039-000

08-31-05 rev 0.9b RKT

01-07-05 rev 1.0 RKT

05-26-09 rev 2.5 BW/CN



Axia Audio, a Telos Company • 2101 Superior Ave. • Cleveland, Ohio, 44114, USA • +1.216.241.7225 • www.AxiaAudio.com